

LINEA CONTROL

T90cn-5

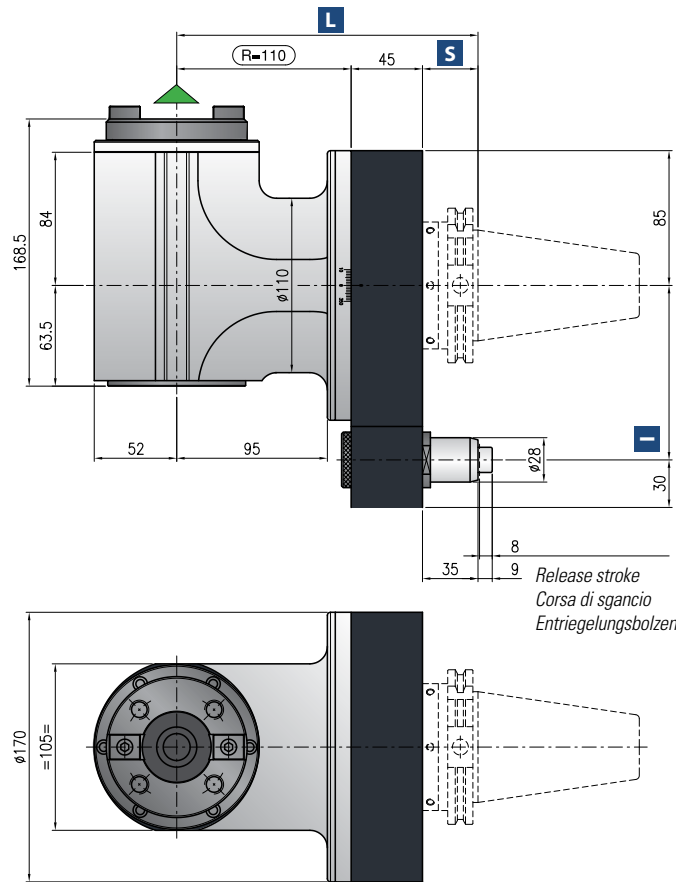

Minimum diameter without tool
Diametro minimo senza utensile
Durchmesser min. ohne Werkzeug

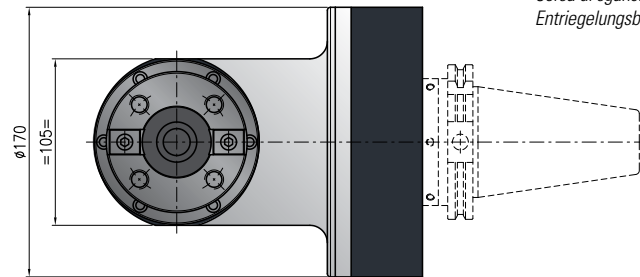
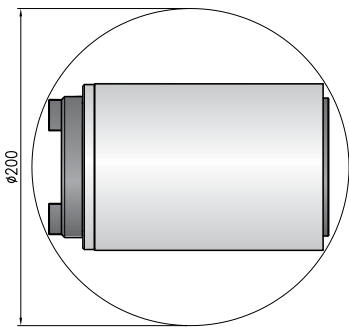

Release stroke
Corsa di sgancio
Entriegelungsbolzen

- Ratio
Rapporto / Verhältnis
1:1
- RPM
Velocità / Drehzahl max.
3.000 min⁻¹
- Max. axial load
Max. carico assiale / Max. Axialbelastung
1.800 N
- Torque
Momento torcente / Drehmoment
100 Nm
- Weight
Peso / Gewicht
22 kg
- Collet
Pinza / Spannzange
ISO 40

*** STANDARD EQUIPMENT INCLUDES:**

- Wooden case - wrenches - Grease tube - Instruction book
- Cassa legno - Ghiera ER chiavi di servizio - Tubetto di grasso - Libro istruzioni
- Holzkiste - Schraubenschlüssel - Tube mit Fett - Bedienungsanleitung

Possibilità refrigerante / Internal coolant / Innere Kühlmittelzufuhr - Max. 12 bar

Direction of rotation same as machine spindle / senso di rotazione uguale al mandrino / Drehrichtung gleich wie Antriebsspindel

Shank/Cono/Aufnahme	DIN-69871	CAT	MAS-BT	HSK		CAPTO
Size/Grandezza/Größe	50		50	80	100	C8
I	110		110	110	110	80-110
S	35		41	42	45	40
L	190		196	197	200	195

*optional

Non interchangeable input drive shank/ Coni di attacco non intercambiabili/ Nicht wechselbare Aufnahme

Option / Opzione / Option



bar max
12

Coolant through pin
Refrigerante attraverso il perno
Kühlmittelzufuhr durch Bolzen



bar max
12

Coolant through pin and spindle
Refrigerante interno attraverso utensile
Kühlmittelzufuhr durch Bolzen und Spindel



min⁻¹
6.000

High speed optional RPM max.
Opzione alta velocità RPM max.
Drehzahl max.



HSK-63

Quick Change
Attacco rapido
Schnellwechsellaufnahme