

# LINEA MODULAR

## T90-3,5 2U

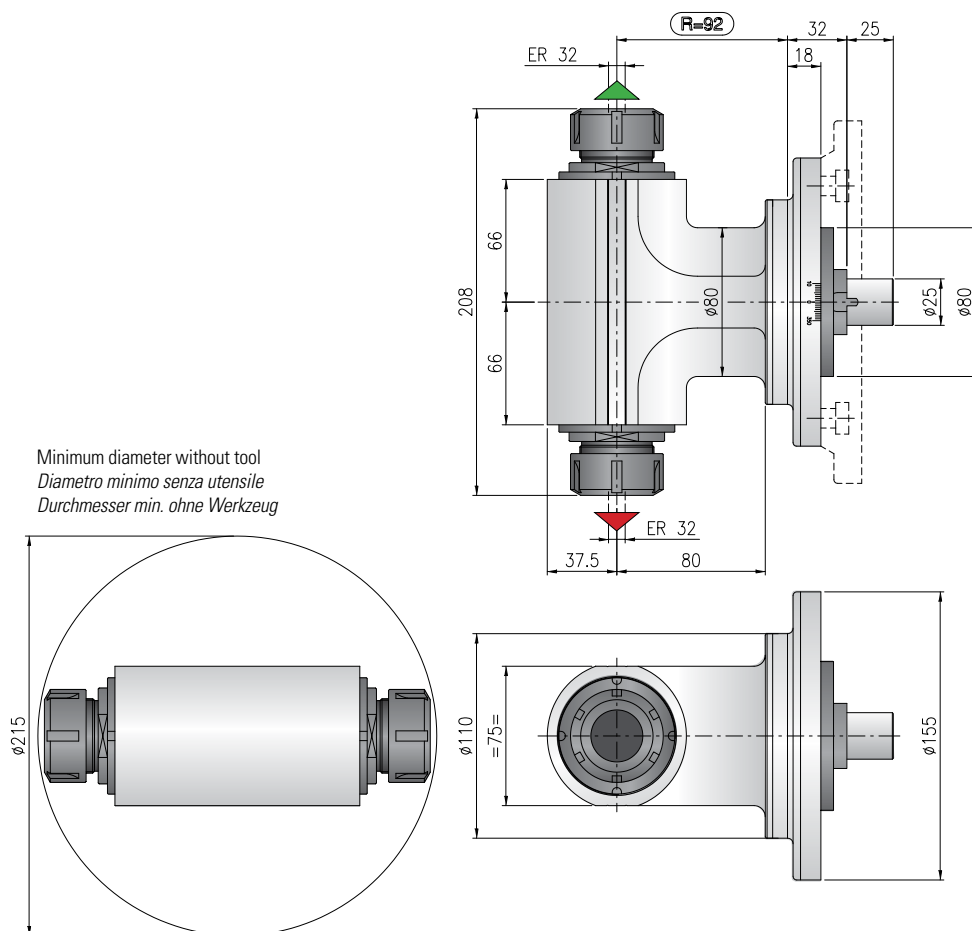

- Ratio  
Rapporto / Verhältnis  
**1.1**
- RPM  
Velocità / Drehzahl max.  
**4.000 min<sup>-1</sup>**
- Max. axial load  
Max. carico assiale / Max. Axialbelastung  
**1.250 N**
- Torque  
Momento torcente / Drehmoment  
**50 Nm**
- Weight  
Peso / Gewicht  
**12 kg**
- Collet  
Pinza / Spannzange  
**ER-32 ø 2/20 mm**

**\* STANDARD EQUIPMENT INCLUDES:**

- Special bag - wrenches - Grease tube - Instruction book
- Bauletto - Ghiera ER chiavi di servizio - Tubetto di grasso - Libro istruzioni
- Spezialtasche - Schraubenschlüssel - Tube mit Fett - Bedienungsanleitung

- Direction of rotation same as machine spindle / senso di rotazione uguale al mandrino / Drehrichtung gleich wie Antriebsspindel
- Direction of rotation opposite to machine spindle / senso di rotazione contrario al mandrino / Drehrichtung entgegen Antriebsspindel

Shank/Cono/Aufnahme	DIN-69871	CAT	MAS-BT	HSK	CAPTO	KM

**Option / Opzione / Option**



min<sup>-1</sup>  
**6.000**

High speed optional RPM max.  
Opzione alta velocità RPM max.  
Drehzahl max.



Ø mm  
**27**

Arbor output  
Porta fresa  
Fräseraufnahme



Ø mm max.  
**20**

Weldon output  
Weldon  
Weldon-Aufnahme



**HSK-40**

Quick Change  
Attacco rapido  
Schnellwechselfaufnahme